



COMMUNITY DEVELOPMENT LIGHTING PROJECT
GVB IFB 2024-009

Addendum No. 1

September 9, 2024

**THIS ADDENDUM NO. 1 SHALL FORM A PART OF THE CONTRACT DOCUMENTS.
FAILURE BY ANY BIDDER TO ACKNOWLEDGE RECEIPT OF THIS ADDENDUM IN THIS BID
SHALL BE GROUNDS FOR DISQUALIFICATION.**

Addendum No. 1 is issued to replace the Invitation for Bid issued on September 6, 2024, which did not include the lighting technical specifications in Appendix A. The attached Invitation for Bid supersedes and replaces the one originally issued.

Deadline for submission of bid offers for GVB IFB 2024-009 is on or before 12:00 p.m. on September 27, 2024.



CARL T. C. GUTIERREZ
President and CEO

FOR POTENTIAL BIDDERS

**PLEASE SIGN AND INCLUDE IN THE BID SUBMISSION AS PROOF OF ACCEPTANCE AND ACKNOWLEDGEMENT
OF ADDENDUM NO. 1.**

Printed Name

Company Name

Signature

Date

INVITATION FOR BID

COMMUNITY DEVELOPMENT LIGHTING PROJECT

GVB IFB 2024-009

ADDENDUM NO. 1
(replaces and supersedes original IFB)

| GUAM VISITORS BUREAU INVITATION FOR BID | |
|---|--|
| IFB Number: GVB IFB 2024-009 | IFB Title: COMMUNITY DEVELOPMENT LIGHTING PROJECT |
| IFB Due Date and Time: September 27, 2024; 12:00 p.m. ChST | Number of Pages: 35; affidavits and forms in this package, along with Appendices A & B. Appendices C and D attached separately. |
| ISSUING AGENCY INFORMATION | |
| GUAM VISITORS BUREAU | Issue Date: September 6, 2024 |
| CARL T. C. GUTIERREZ President and CEO | 401 Pale San Vitores Road Tumon, Guam 96913 Phone: (671) 646-5278 Fax: (671) 646-8861 Website: www.guamvisitorsbureau.com |
| INSTRUCTIONS TO BIDDERS | |
| Delivery of Bid <i>By U.S. Mail or Deliver Only to the attention of:</i> Carl T. C. Gutierrez President and CEO Guam Visitors Bureau 401 Pale San Vitores Road Tumon, Guam 96913 | Mark Face of Envelope/Package: COMMUNITY DEVELOPMENT LIGHTING PROJECT IFB Number: GVB IFB 2024-009 IFB Due Date: September 27, 2024; 12:00 p.m. ChST Special Instructions: <i>Please process proposal submission in accordance with Sections 4 and 5 of the Notice/Instructions to Bidders. Failure to do so will mean disqualification and rejection of bid.</i> |
| BIDDERS MUST COMPLETE INFORMATION BELOW AND RETURN THIS COVERSHEET WITH IFB RESPONSE | |
| Bidder Name/Mailing Address: | Authorized Bidder Signatory: <small>(PLEASE PRINT NAME AND SIGN IN INK)</small> |
| Bidder Title: | Bidder Email Address: |
| Bidder Telephone Number: | Bidder FAX Number: |

TABLE OF CONTENTS

| | <u>PAGE</u> |
|---|-------------|
| SECTION I: INVITATION FOR BID | 4 |
| SECTION II: NOTICE/INSTRUCTIONS TO BIDDERS | 5 |
| SECTION III: GENERAL PROVISIONS | 10 |
| SECTION IV: PROPOSAL | 14 |
| SECTION V: BID FORM | 15 |
| SECTION VI: BID BOND..... | 19 |
| SECTION VII: AUTHORIZED CONTACT | 20 |
| SECTION VIII: AFFIDAVITS/FORMS..... | 22 |
| SECTION IX: PAST PERFORMANCE QUESTIONNAIRE..... | 28 |
| APPENDIX A: SCOPE OF WORK AND TECHNICAL SPECIFICATIONS..... | 30 |
| APPENDIX B: BID SCHEDULE..... | 34 |
| <u>ATTACHED SEPARATELY</u> | |
| APPENDIX C: U.S. DEPARTMENT OF LABOR WAGE & DETERMINATION LISTING | |

| | |
|------------------|---------------------------|
| SECTION I | INVITATION FOR BID |
|------------------|---------------------------|

**COMMUNITY DEVELOPMENT LIGHTING PROJECT
 GVB IFB 2024-009**

The Guam Visitors Bureau ("GVB"), a public, non-stock, non-profit, membership corporation, will receive sealed bids from qualified businesses for the **COMMUNITY DEVELOPMENT LIGHTING PROJECT** according to the following schedule:

| | |
|---|---|
| FRIDAY, September 6, 2024 | Bid Documents (USB format) available at GVB office or via the GVB website |
| WEDNESDAY, September 11, 2024; 12:00 p.m. | Deadline to submit written questions; GVB response will be posted on the website and emailed to all registered participants |
| FRIDAY, September 27, 2024; 12:00 p.m. ChST | Deadline to submit bids; IFB bid opening |
| Determination of Lowest Responsible and Most Responsive Bidder. | Confirmed after Administrative Review and Certification of Abstract. |

Pursuant to 5GCA §5220(a), the **Invitation for Bid** package can be **downloaded at no cost** from GVB's website at https://go.opengovguam.com/bids/bids_list/gvb or obtained (in USB format) at the GVB Office, 401 Pale San Vitores Road, Tumon, Guam, 8:00 AM – 5:00 PM, Monday – Friday, excluding Guam holidays. A non-refundable \$25.00 fee is required for each packet picked up at the GVB office payable in US\$ cash, bank wire transfer or major credit card (Visa MasterCard, Discover, JCB).

Questions, if any, should be made in writing to the President and CEO, which can be dropped off at the GVB office; emailed to procurement@visitguam.org; or sent by fax to 671-646-8861 according to the timeline provided in the IFB packet.

GVB hereby notifies all bidders that it will affirmatively ensure that minority business enterprises will be afforded full opportunity to submit a response to this request for proposal and will not be discriminated against on the grounds of race, color or national origin in consideration for an award.

GVB reserves the right to reject any or all bids, solicit new bids, waive minor informalities or irregularities or award **GVB IFB 2024-009 COMMUNITY DEVELOPMENT LIGHTING PROJECT**, in whole or in part. Except to the above person named, direct or indirect contact with the GVB Management or Staff, Board Member, or any person participating in the selection process is prohibited.

Bid submission deadline is at 12:00 p.m. Chamorro Standard Time on FRIDAY, September 27, 2024. Immediately thereafter, all bid submissions will be opened by the President and CEO in the GVB Main Conference Room. Award will be confirmed after bid analysis and verification of bid.

/s/ **CARL T. C. GUTIERREZ**
 President and CEO



SECTION II NOTICE/INSTRUCTIONS TO BIDDERS

1. DESCRIPTION OF WORK

Project consists of furnishing all necessary labor, materials, equipment, tools and services for the **COMMUNITY DEVELOPMENT LIGHTING PROJECT** as described in the attachments provided with this Invitation for Bid:

- a. APPENDIX A – Scope of Work (SOW) and Bid Specifications
- b. APPENDIX B – Bid Schedule

ATTACHED SEPARATELY

- c. APPENDIX C – US DOL Wage Listing (must be included in submission)

2. PRE-BID CONFERENCE

There is a no pre-bid conference for this solicitation.

3. QUESTIONS AND INTERPRETATIONS

Documents forming the contract are complementary and unitary and what is called for by one shall be as binding as if it were called by all and are intended to include all details of labor and material reasonably necessary for proper execution of the work. Questions concerning the Bid Documents shall be submitted in writing, via hand delivery, email to procurement@visitquam.org or fax at (671) 646-8861, to the President and CEO. Replies will be issued to all bidders of record to the solicitation. Questions must be received at GVB no later than 12:00 p.m. on **September 27, 2024**.

4. SEALED BIDS

All bid proposals for this project shall be enclosed in a sealed envelope marked "**COMMUNITY DEVELOPMENT LIGHTING PROJECT**" and shall be submitted at the place and time indicated in the Invitation to Bid.

A second sealed envelope marked "**BID PRICE**" shall also be included in the proposal package, which must contain:

- a. BID SCHEDULE
- b. BID FORM
- c. BID BOND (or CASHIER'S CHECK)

5. BID PROPOSAL SUBMITTAL ITEMS

The bidder is required to complete and submit a bid proposal package, in duplicate, containing the following items:

- a. **COVER LETTER** to confirm commitment and bid submission for this project, which must be signed by an authorized representative of the company.
- b. **BID PROPOSAL FORM** (see Section IV)
- c. **BUSINESS/CONTRACTOR'S LICENSE** (proof of ability to do business on Guam and perform services required for this project)

- d. Completed **AFFIDAVITS/FORMS** (see Section VIII), *including a copy of the latest U.S. DOL Wage Determination Listing, which will be included as part of the bidder's submission during administrative review.*
- e. **EQUIPMENT DATA** (necessary for this project)
- f. **STAFF ORGANIZATIONAL CHART**
- g. **PROJECT REFERENCE LIST** (see last paragraph of this section)*

Bidder must submit its proposal on the forms furnished by GVB, if provided; otherwise, please add pages as necessary to comply with the requested information. All blank spaces on the Proposal Forms and Bid Schedule must be correctly filled in for each and every item where a quantity is given. In case of an error in the extension or prices, unit price will govern. A conditional or qualified bid is non-responsive and will not be accepted. The proposal signatory must initial all erasures or other changes in the proposal.

Bidder shall sign his proposal in the blank space provided therefor. If proposal is made by a partnership or corporation, name and address of the partnership or corporation shall be shown together with names and addresses of the partners or officers. If proposal is made by a partnership, it shall be signed by one of the partners; if made by a corporation, it shall be signed by one of the officers thereof. If proposal is made by an authorized representative, an affidavit regarding delegation of authority for this bid must accompany the submission. Failure to do so will mean disqualification and rejection of the bid.

*Bidder shall send the *Past Performance Questionnaire* (See Section IX) to those companies on their project reference list. Each reference will be asked to complete and send their confidential response directly to procurement@visitguam.org and *will be included as part of the bidder's submission during administrative review.*

6. **RIGHT TO ACCEPT AND REJECT BIDS**

GVB reserves the right in accordance with law and regulation and in its sole and absolute discretion, to reject any and all bids, or to accept that bid, if any, which in its sole and absolute judgment will, under all circumstances, best serve GVB's interests. In the event that the successful bidder fails to execute contract upon his part, the GVB, after declaring the security deposit of such bidder forfeited, reserves the option to accept the bid of the second ranked bidder within ten (10) days from such default, in which case such acceptance shall have same effect as to such bidder as though he were the originally successful bidder.

7. **BID GUARANTEE**

Bids shall be accompanied by a bid guarantee of not less than fifteen percent (15%) of the amount of the bid, which may be a Bid Bond (form enclosed), official bank check or cashier's check, made payable to Guam Visitors Bureau. Attorneys-in-Fact who sign bid bonds shall file with each bond a certified and effective dated copy of their Power of Attorney. Failure to do so will mean disqualification and rejection of the bid.

Such bid bond or check shall serve to guarantee:

- a. that the bidder shall not withdraw his bid for a period of 60 days after the scheduled closing time for the receipt of bids;
- b. that if his bid is accepted, he will enter into a formal contract with GVB, in accordance with the contract for work included as part of the Contract Documents. In the event of withdrawal of said

bid within said period, or failure to enter into said contract, bidder shall be liable to GVB for the full amount of the bid guarantee as representing damage to the GVB on account of the default of the bidder in any particular case hereof.

Bid guarantee shall be returned to all except the three lowest bidders within three (3) days after formal opening of bids. Remaining Bid Bonds and check will be returned to the three lowest bidders within forty-eight (48) hours after GVB and the accepted Bidder have executed an intent to award the contract by the GVB.

A surety company holding a certificate of authority from the United States Secretary of Treasury or from a company acceptable to the GVB shall execute guarantee Bonds and include the bond number for the actual bond securing this bid on the Bid Bond Form provided. Checks or money order submitted as a bid guarantee shall be made payable to the Guam Visitors Bureau.

8. **ALL OR NONE BIDS**

Only all or none bids will be accepted. Contractors that do not enter a bid amount for every bid item will be deemed non-responsive and their bids will not be accepted. Only one Contractor will be awarded the contract. Multiple or alternate bids will not be considered (2 GAR, Division 4 §§3102(d)).

9. **LATE BIDS AND MODIFICATIONS OF WITHDRAWALS**

Bids and modifications or withdrawals thereof received at GVB after the exact time set for opening of bids will not be accepted. Bids may be withdrawn by written request received from bidders prior to the time set for opening bids.

10. **LIQUIDATED DAMAGES**

It is understood and agreed that liquidated damages shall be assessed against the Contractor for non-performance in accordance with the Liquidated Damages clause in the contract.

11. **BID SECURITY**

The successful bidder shall be required to furnish a bid bond amounting to fifteen percent (15%) of the total bid submitted. See Section IV: Proposal for more detailed information.

12. **STATUTORY REQUIREMENTS**

The Contractor and any subcontractors employed in completion of the project shall comply with all applicable and Federal and local laws.

13. **NOTICE OF LOCAL PREFERENCE**

In accordance with 5 Guam Code Ann. §5008, please take notice that the Guam Visitors Bureau will apply a local preference to this procurement. Accordingly, bidder requesting such a preference should do so in writing and as part of their offer.

14. **NOTICE REGARDING SERVICE DISABLED VETERANS**

In accordance with 5 Guam Code Ann. §5011, please take notice that the Guam Visitors Bureau will apply a service-disabled veteran's preference to this procurement. Accordingly, bidders requesting such a preference should do so in writing, and as part of their offer.

15. **REPRESENTATION REGARDING GRATUITIES AND KICKBACKS**

(a) Gratuities. It shall be a breach of ethical standards for any person to offer, give or agree to give any employee or former employee, or for any employee or former employee to solicit, demand, accept or agree to accept from another person, a gratuity or an offer of employment in connection with any decision, approval, disapproval, recommendation, preparation of any part of a program requirement or a purchase request, influencing the content of any specification or procurement standard, rendering of advice, investigation, auditing, or in any other advisory capacity in any proceeding or application, request for ruling, determination, claim or controversy, or other particular matter, pertaining to any program requirement or a contract or subcontract; or to any solicitation or proposal therefor.

(b) Kickbacks. It shall be a breach of ethical standards for any payment, gratuity or offer of employment to be made by or on behalf of a subcontractor under a contract to the prime contractor or higher tier subcontractor or any person associated therewith, as an inducement for the award of a subcontract or order.

16. **PROHIBITION AGAINST CONTINGENT FEES**

(a) Contingent Fees. It shall be a breach of ethical standards for a person to be retained, or to retain a person, to solicit or secure a territorial contract upon an agreement or understanding for a commission, percentage, brokerage or contingent fee, except for retention of bona fide employees or bona fide established commercial selling agencies for the purpose of securing business.

(b) Representation of Contractor. Every person, before being awarded a territorial contract, shall represent, in writing, that such person has not retained anyone in violation of Subsection (a) of this Section. Failure to do so constitutes a breach of ethical standards.

17. **REPRESENTATION REGARDING ETHICAL STANDARDS FOR GOVERNMENT EMPLOYEES AND FORMER GOVERNMENT EMPLOYEES**

The bidder, offeror or contractor represents that it has not knowingly influenced and promises that it will not knowingly influence a government employee to breach any of the ethical standards set forth in 5 GCA Chapter 5, Article 11 (Ethics in Public Contracting) of the Guam Procurement Act and in Chapter 11 of the Guam Procurement Regulations.

18. **DISCLOSURE OF MAJOR SHAREHOLDERS AFFIDAVIT**

As a condition of bidding, any partnership, sole proprietorship or corporation doing business with the Government of Guam shall submit an affidavit executed under oath that lists the name and address of any person who has held more than fifteen percent (15%) of the outstanding interest or shares in said partnership, sole proprietorship or corporation at any time during the twelve (12) month period immediately preceding submission of a bid. The affidavit shall contain the number of shares or the percentage of all assets of such partnership sole proprietorship or corporation which have been held by each such person during the twelve (12) month period.

In addition, affidavit shall contain the name and address of any person who has received or is entitled to receive a commission, gratuity or other compensation for procuring or assisting in obtaining business related to the bid or the bidder and shall also contain the amounts of any such commission, gratuity or other compensation. Affidavit shall be open and available to the public for inspection and copying. All bidders are required to submit a current affidavit in the form attached disclosing required information. Failure to do so will mean disqualification and rejection of the bid.

19. **NON-COLLUSION AFFIDAVIT/CONFLICT OF INTEREST DISCLOSURES**

By submitting an offer, the bidder certifies that the price submitted was independently arrived at without collusion. Bidders must submit a non-collusion affidavit and conflict of interest disclosures in the form provided with this Invitation for Bids. Failure to submit said affidavit and disclosures shall result in the bidder's proposal to be deemed non-responsive to this procurement.

20. RESTRICTION AGAINST CONTRACTORS EMPLOYING CONVICTED SEX OFFENDERS FROM WORKING AT GOVERNMENT OF GUAM VENUES

The bidder must submit with their proposal an affidavit (see attached) acknowledging their responsibilities under Guam statute 5 Guam Code Ann. § 5253. Restriction Against Contractors Employing Convicted Sex Offenders from Working at Government of Guam Venues. Per this statute, the bidder must affirm that:

1. that no person providing services on behalf of the contractor has been convicted of a sex offense under the provisions of Chapter 25 of Title 9 GCA or an offense as defined in Article 2 of Chapter 28, Title 9 GCA, or an offense in another jurisdiction with, at a minimum, the same elements as such offenses, or who is listed on the Sex Offender Registry; and
2. that if any person providing services on behalf of the contractor is convicted of a sex offense under the provisions of Chapter 25 of Title 9 GCA or an offense as defined in Article 2 of Chapter 28, Title 9 GCA or an offense in another jurisdiction with, at a minimum, the same elements as such offenses, or who is listed on the Sex Offender Registry, that such person will be immediately removed from working at said agency and that the administrator of said agency be informed of such within twenty-four (24) hours of such conviction.

21. CANCELLATION OF THIS INVITATION FOR BIDS

Please take note that this Invitation for Bids may be cancelled as provided in Guam procurement law and Guam procurement rules and regulations. Prospective bidders are directed to review relevant law, statute and regulation, particularly 2 GAR, Div. 4 & Reg. §3115 and §3121(e)(1)(G).

22. WAGE AND BENEFIT DETERMINATION

(a) In such cases where the government of Guam enters into contractual arrangements with a sole proprietorship, a partnership or a corporation for the provision of a service to the government of Guam, and in such cases where the contractor employs a person(s) whose purpose, in whole or in part, is the direct delivery of service contracted by the government of Guam, then the contractor shall pay such employee(s) in accordance with the Wage Determination for Guam and the Northern Mariana Islands issued and promulgated by the U.S. Department of Labor for such labor as is employed in the direct delivery of contract deliverables to the government of Guam.

(b) The Wage Determination most recently issued by the U.S. Department of Labor at the time a contract is awarded to a contractor by the government of Guam shall be used to determine wages, which shall be paid to employees pursuant to this Article. Should any contract contain a renewal clause, then at the time of renewal adjustments, there shall be made stipulations contained in that contract for applying the Wage Determination, as required by this Article, so that the Wage Determination promulgated by the U.S. Department of Labor on a date most recent to the renewal date shall apply. In addition to the Wage Determination detailed in this Article, any contract to which this Article applies shall also contain provisions mandating health and similar benefits for employees covered by this Article, such benefits having a minimum value as detailed in the Wage Determination issued and promulgated by the U.S.

Department of Labor and shall contain provisions guaranteeing a minimum of ten (10) paid holidays per annum per employee.

23. **ACKNOWLEDGEMENT OF RECEIPT OF AMENDMENTS**

Potential bidders are advised that this Invitation for Bids may, from time to time be altered or supplemented by amendments. Each and all such amendments must be acknowledged by the potential bidder. Failure to do so may result in an offer being deemed non-responsive.

24. **CONTRACT TERM**

The contract shall begin upon the issuance of the Notice to Proceed and end on December 31, 2024, or upon completion of the removal/disposal of old lighting and complete installation of the solar LED lighting panels (see Appendices A and B). If the project timeline needs to be extended due to unforeseen circumstances and through no fault of the Contractor, GVB maintains the right to extend the agreement beyond the contract term on a month-to-month basis, as determined necessary by the Chief Procurement Officer, to allow time to complete the project.

SECTION III GENERAL PROVISIONS

1. **DEFINITIONS**

- a. The term "GVB" as used herein shall mean the Guam Visitors Bureau. The term "Bureau" as used herein shall mean the Guam Visitors Bureau.
- b. The term "Contracting Officer" as used herein shall mean the President and CEO of GVB, the person executing this Contract on behalf of the GVB and includes a duly appointed successor or authorized representative.
- c. The term "Contractor" shall mean the party (individual, corporation, joint venture, or partnership) who has entered into the Contract with the GVB.
- d. The term "Contract" shall mean the written agreement covering the performance of the project by the Contractor, including the furnishing of labor, materials and equipment in connection therewith. It shall include the invitation and solicitation, these general requirements and provisions, the notice to contractors, the bid, wage schedule, list of subcontractors, the award, the plans, the general specifications, the bond, any addendum and any written order. It shall also include all amendments to the Contract by supplemental agreement thereto in writing.
- e. "Project" shall mean the work to be performed as described in the general specifications.
- f. The term "Work" shall mean all equipment, materials, operations and incidental activities necessary for the completion of any part or all of the project.
- g. The term "Project Manager" shall mean the duly authorized representative of the Contracting Officer who is responsible for the administration of the Contract.

2. **PERMITS AND RESPONSIBILITIES**

The Contractor shall, without additional expense to the GVB, be responsible for obtaining any necessary

licenses and permits and for complying with any applicable Federal and local codes and regulations, in connection with execution of the work. He shall be similarly responsible for all damage to persons or property that occurs as a result of his fault or negligence. He shall take proper safety and health precautions to protect the work, the workers, the public, and the property of others. He shall also be responsible for all materials delivered and work performed until completion and acceptance of the entire project.

3. CONDITIONS AFFECTING THE WORK

Contractor shall be responsible for having taken steps reasonably necessary to ascertain the nature and location of the work, and the general and local conditions, which can affect the work or cost thereof. Any failure by the Contractor to do so will not relieve him from responsibility for successfully performing the work without additional expense to GVB.

GVB assumes no responsibility for any understanding or representations concerning conditions made by any of its officers or agents prior to execution of this Contract, unless such understanding or representations by GVB are expressly stated in the Contract.

4. ADDITIONAL BOND SECURITY

If any surety upon any bond furnished in connection with this Contract becomes unacceptable to the GVB, or if any such surety fails to furnish reports as to his financial condition from time to time as requested by the GVB, the Contractor shall promptly furnish such additional security as may be required from time to time to protect the interests of the GVB and of persons supplying labor or materials in the prosecution of the work contemplated by this Contract.

5. COVENANT AGAINST CONTINGENT FEES

The contractor represents that it has not retained a person to solicit or secure a territorial contract upon an agreement or understanding for a commission, percentage, brokerage, or contingent fee, except for retention of bona fide employees or bona fide established commercial selling agencies for the purpose of securing business.

6. OFFICIALS NOT TO BENEFIT

No member of the Government of Guam Legislature or the Governor of Guam shall be admitted to any share of this Contract, or to any benefit that may arise therefrom; but this provision shall be construed to extend to this Contract if made with a corporation for its general benefit.

7. DISPUTES

- a. All controversies between the GVB and the contractor which arise under, or are by virtue of, this contract and which are not resolved by mutual agreement, shall be decided by the GVB in writing, within 60 days after written request by the contractor for a final decision concerning the controversy; provided, however, that if the GVB does not issue a written decision, within 60 days after written request for a final decision, or within such longer period as may be agreed upon by the parties, then the contractor may proceed as if an adverse decision had been received.
- b. The GVB shall immediately furnish a copy of the decision to the contractor, by certified mail, return receipt requested, or by any other method that provides evidence of receipt.

- c. Any such decision shall be final and conclusive, unless fraudulent, or: (i) the contractor brings an action seeking judicial review of the decision in the Superior Court of Guam.
- d. The contractor shall comply with any decision of the GVB and proceed diligently with performance of this contract pending final resolution by the Superior Court of Guam of any controversy arising under, or by virtue of, this contract, except where there has been a material breach of the contract by the territory; provided, however, that in any event the contractor shall proceed diligently with the performance of the contract where the GVB has made a written determination that continuation of work under the contract is essential to the public health and safety.

8. CONTRACT AND BONDS

If the successful bidder fails to satisfactorily execute the required forms of contract within the time established in the bid, the GVB may proceed to have the required work performed by contract or otherwise, and the bidder to whom the award was originally made shall be liable for any excess cost to the GVB and the bid guaranty shall be available toward offsetting such excess cost.

9. WORKING HOURS

Work shall be conducted during normal working hours Monday through Friday and should not exclude the possibility of working after hours and on weekends.

10. FEES AND CHARGES

Contractor shall obtain and pay all fees and charges for connections to outside services and for the use of property outside of the work site.

11. FEDERAL AND TERRITORY OF GUAM TAXES

Except as may be otherwise provided in this Contract, the Contract price includes all applicable Federal and local taxes and duties.

12. ACCIDENT PREVENTION – PUBLIC SAFETY

In performance of the Contract, Contractor shall comply with applicable provisions of the U.S Occupational Safety and Health Act (OSHA) and shall take all precautions necessary to protect persons and property.

13. DISPUTES CONCERNING LABOR STANDARDS

Dispute arising out of the Labor Standards provisions of this Contract shall be subject to the clause entitled "Disputes" of this Contract except to the extent such disputes involve classifications or wage rates, which questions shall be referred to the Contracting Officer.

14. NONCOMPLIANCE WITH CONTRACT REQUIREMENTS

In the event the Contractor, after receiving written notice from the Contracting Officer of noncompliance with any requirement of this Contract, fails to initiate promptly such action as may be appropriate to comply with the specific requirement within a reasonable period of time, the Contracting Officer shall have the right to order the Contractor to stop all other work and correct the deficiency. The Contractor will not be entitled to any extension of contract time or payment for any costs incurred as a result of being ordered to stop work for such cause.

15. INSURANCE – LIABILITY TO THIRD PERSONS

The Contractor and his subcontractors shall procure thereafter maintain workmen's compensation, builders' risk, comprehensive general liability (bodily damage), and fire and extended coverage insurance, with respect to performance under this Contract; provided, that the Contractor may, with the approval of the Contracting Officer, maintain a self-insurance program. All insurance required pursuant to the provisions of this paragraph shall be in such form in such amounts, and for such periods of time as the Contracting Officer may, from time to time, require or approve, and with insurers approved by the Contracting Officer.

- a. Automobile liability insurance in an amount not less than \$500,000 Combined Single Limit (CSL) for bodily injury or death per person and for damages to property for each occurrence.
- b. Comprehensive general liability insurance with minimum limits of \$1,000,000 Combined Single Limit (CSL) for bodily injury or death and for property damage per occurrence.
- c. Workmen's Compensation. Contractor shall take out adequate workmen's compensation insurance for all of the employees who will be engaged in work at the site of the project and in case any part of such Contractor's contract is sublet, the Contractor will require his subcontractor's employees who will be so engaged, unless the latter's employees are protected by the principal contractor's insurance.

The comprehensive general and automobile liability policies shall contain a provision worded as follows: The insurance company waives any right of Subrogation against the GVB, which may arise by reason of any payment under this policy. When a subcontractor is utilized, Contractor shall procure and maintain during contract period, insurance coverage with same bodily injury and property damage liability limits specified above, covering accidents caused by actions of subcontractor or employees.

All of the insurance policy or policies herein prescribed shall be procured and maintained at no cost to the GVB and shall have the GVB named as additional insured; provided that, where the GVB may not be named as an insured under the rules applicable to any policy or policies, the Contractor shall procure and maintain at no expense to the GVB contractor's protective insurance providing the GVB with the same coverage's and limits of liability as are required herein for the Contractor. A copy of such policy or policies shall be furnished to the GVB at the time prescribed in the contract documents. Such policy or policies shall contain an endorsement to the effect that the insuring company will notify GVB thirty (30) days prior to the effective date of any cancellation of such policy or policies or any change in their provisions.

16. FOREIGN CORRUPT PRACTICES ACT

As a condition of contract, contractor will agree to abide by the Foreign Corrupt Practices Act (FCPA), specifically, the anti-bribery provisions of the FCPA, which prohibit the willful use of the mails or any means of instrumentality of interstate commerce corruptly in furtherance of any offer, payment, promise to pay, or authorization of the payment of money or anything of value to any person, while knowing that all or a portion of such money or thing of value will be offered, given or promised, directly or indirectly, to a foreign official to influence the foreign official to do or omit to do an act in violation of his or her lawful duty, or to secure any improper advantage in order to assist in obtaining or retaining business for or with, or directing business to, any person.

*** END OF GENERAL PROVISIONS ***

SECTION IV **PROPOSAL SUBMITTED BY:**

Date: _____

Gentlemen:

The undersigned (hereafter called the Bidder), a _____ (Corporation, Partnership or Individual) organized and/or licensed to do business under the laws of the Government of Guam hereby proposes and agrees to furnish all the necessary labor, materials, equipment, tools and services necessary for the performance of the **COMMUNITY DEVELOPMENT LIGHTING PROJECT**, all in accordance with the Bid Documents for the prices stated in the itemized Bid Schedule forms attached hereto, plus any and all sums to be added and/or deducted resulting from all extra and/or omitted work in accordance with the unit and/or lump sum prices stated in the itemized Bid Schedule forms attached hereto.

The undersigned has visited and inspected the location of the proposed work and reviewed the Bid Documents and is familiar with and knowledgeable of the local conditions at the place where the work is to be performed.

The individual **Bid Bond** attached, with our endorsement, in the sum of not less than fifteen percent (15%) of the amount of each Proposal, *is furnished to GVB as a guarantee that the Agreement will be executed* and a Performance Bond shall be furnished within fifteen (15) days after award of the Contract to the undersigned. In the event that this Proposal is accepted, and the undersigned bidder shall fail to execute the contract and furnish a satisfactory Performance Bond under the conditions and within the time specified in this Proposal, the Bid Bond shall be forfeited, as liquidated damages for the delay and additional work and costs caused thereby in obtaining another bidder, said amount being beforehand determined as being reasonable and containing no penalties.

If written notice of the acceptance of this bid is mailed, telegraphed or delivered to the undersigned within sixty (60) days after the opening thereof, the undersigned agrees to execute the form of Agreement included as one of the Contract Documents, and to furnish a **Performance Bond** *in an amount equal to one hundred percent (100%) of the Contract Amount*, within fifteen (15) days after receipt of such notice.

If awarded the Contract, the undersigned agrees to perform the work for the duration of the contract period and any extensions thereto upon commencement of the contract time as defined in the Contract.

The undersigned understands that the GVB reserves the right to reject any or all Bids or to waive any informality or technicality in any Bid in the interest of the GVB. All required affidavits and forms are included in this bid proposal.

RESPECTFULLY SUBMITTED BY:

(CONTRACTOR)

(BY)

(TITLE)

(BUSINESS ADDRESS)



SECTION V **BID FORM SUBMITTED BY:**

PROJECT: COMMUNITY DEVELOPMENT LIGHTING PROJECT

**TO: President and CEO
Guam Visitors Bureau
Tumon, Guam**

The undersigned bidder, having examined all pertinent Contract Documents relating to Invitation for Bid Number 2024-009, proposes to provide all labor, materials, equipment, tools, appliances, transportation, storage and items incidental to completing all work based on the Proposal and Bid Schedule consisting of the combination of lump sum and unit price items for the following:

Performance as per Bid Documents and Bid Schedule for one year (Base Bid):

_____ Dollars (\$_____).
(TOTAL OF MATERIALS AND LABOR AND ALL OTHER COSTS)

Bidder hereby further agrees to commence work under this Contract on the date specified in the written "Notice to Proceed" by GVB and to fully complete the work designated for performance within the time stipulated in the Contract Documents. Bidder further agrees to pay liquidated damages in accordance with the Liquidated Damages section of the General Provisions.

By submission of this bid, each bidder and each person signing on behalf of any bidder and in the case of a joint bid each party thereto certified as to its own organization, certifies and affirms as true to the best of his knowledge and belief:

- a. The prices in this bid have been arrived at independently without collusion, consultation, communication, or agreement for the purpose of restricting competition, as to any other matter relating to such prices with any other bidder or with any competitor.
- b. Unless otherwise required by law, the prices which have been quoted in this bid have not been knowingly disclosed by the bidder or to any competitor; and no attempt has been made or will be made by the bidder to induce any other person, partnership or corporation to submit or not to submit a bid for the purpose of restricting competition.
- c. That if the product of the UNIT PRICE bid by the number of units does not equal the total amount named by a bidder of any item, it will be assumed that the error was made in computing the product of the unit price and the number of units. The named UNIT PRICE alone will be considered as representing the bidder's intention and the total amount bid on such item shall be considered to be the amount arrived at by multiplying the UNIT PRICE by the number of units.
- d. All matters for this project of which there is not a special item in the Bid Schedule, shall be considered incidental to and included in the Contractor's bid on any items in the Bid Schedule, as the bidder sees fit.

This bid may be withdrawn at any time prior to the scheduled time for the opening of bids or any authorized postponement thereof.



Dated: _____

BY _____

Address _____



SECTION VI BID BOND

REFERENCE BID BOND #: _____

KNOW all men by these presents, that we

(Name of Contractor)
as Principal, and

(Name of Surety)

as surety are held and firmly bound unto the Guam Visitors Bureau, hereinafter called the GVB, in the penal sum of _____ dollars, lawful money of the United States, for the payment of which sum will and truly be made, we bind ourselves, our heirs, executors, administrators and successors, jointly and severally, firmly by these present.

The condition of this obligation is such that the principal has submitted the accompanying bid dated _____, 20___ for the **COMMUNITY DEVELOPMENT LIGHTING PROJECT**.

THE BID BOND will remain in effect until such time as GVB awards the contract.

In Witness Thereof, the above-bound parties have executed this instrument under their several seals this _____ day of _____, 20___ the name and corporate seal of each corporate party being hereto affixed and these present duly signed by its undersigned representative, pursuant to authority of its governing body.

The rate of premium on this bond is _____ per thousand.

Total amount of premium charged, \$ _____
(The above must be filled in by corporate surety)

IN PRESENCE OF:

(SEAL)
(Individual Principal)

(Business Address)

(Address)

(SEAL)
(Individual Principal)

(Business Address)

(Address)





Attest:

(Corporate Principal)

(Business Address)

AFFIX CORPORATE SEAL

By: _____

Attest:

(Corporate Surety)

(Business Address)

AFFIX CORPORATE SEAL

By: _____



CERTIFICATE AS TO CORPORATE PRINCIPAL

I, _____, certify that I am the _____
_____ secretary of the corporation named as principal in the within
bond; that _____, who signed the said bond on behalf of the
principal was then _____ of said corporation; that I
know his signature, and his signature thereon is genuine; and that said bond was duly signed, sealed and
attested for and in behalf of said corporation by authority of its governing body.

(CORPORATE SEAL)



SECTION VII AUTHORIZED CONTACT

IFB NUMBER: GVB IFB 2024-009

| | |
|------------------|--|
| NAME | |
| TITLE | |
| COMPANY | |
| MAILING ADDRESS | |
| TELEPHONE NUMBER | |
| FACSIMILE NUMBER | |
| EMAIL | |



SECTION VIII AFFIDAVITS/FORMS

**AFFIDAVITS
1 ~ 7**

- 1: Affidavit Disclosing Ownerships and Commissions**
- 2: Affidavit re Non-Collusion**
- 3: Affidavit re No Gratuities or Kickbacks**
- 4: Affidavit re Ethical Standards**
- 5: Declaration re Compliance with U.S. DOL Wage Determination**
- 6: Affidavit re Contingent Fees**
- 7: Restriction Against Contractors Employing Convicted Sex Offenders from Working at Government of Guam Venues**

**ALL FORMS LISTED MUST BE COMPLETED
AND RETURNED IN THE ENVELOPE CONTAINING THE PROPOSAL.**

1. AFFIDAVIT DISCLOSING OWNERSHIP and COMMISSIONS
GVB IFB 2024-009

Name of Offeror Company: _____

CITY OF _____)
) ss
COUNTRY _____)

A. I, the undersigned, being first duly sworn, depose and say that I am an authorized representative of the offeror and that [please check only one]:

- The offeror is an individual or sole proprietor and owns the entire (100%) interest in the offering business.
- The offeror is a corporation, partnership, joint venture, or association known as _____ [please state name of offeror company], and the persons, companies, partners, or joint venturers who have held more than 10% of the shares or interest in the offering business during the 365 days immediately preceding the submission date of the proposal are as follows [if none, please state]:

| <u>NAME</u> | <u>ADDRESS</u> | <u>% of Interest</u> |
|-------------------------------|----------------|----------------------|
| _____ | _____ | _____ |
| _____ | _____ | _____ |
| <u>TOTAL NUMBER OF SHARES</u> | | _____ |

B. Further, I say that the persons who have received or are entitled to receive a commission, gratuity or other compensation for procuring or assisting in obtaining business related to the bid or proposal for which this affidavit is submitted are as follows [if none, please so state]:

| <u>NAME</u> | <u>ADDRESS</u> | <u>Compensation</u> |
|-------------|----------------|---------------------|
| _____ | _____ | _____ |

C. If the ownership of the offering business should change between the time this affidavit is made and the time an award is made or a contract is entered into, then I promise personally to update the discloser required by 5 GCA §5233 by delivering another affidavit to the government.

Date: _____

Signature of one of the following:
Offeror, if the offeror is an individual;
Partner, if the offeror is a Partnership;
Officer, if the bidder is a Corporation.

Subscribed and sworn to before me this _____ day of _____, _____.

Notary Public
My Commission expires _____

(AG Procurement Form 002 (Rev. Nov. 17, 2005))



2. AFFIDAVIT re NON-COLLUSION
GVB IFB 2024-009

Name of Offeror Company: _____

CITY OF _____)
) ss
 COUNTRY _____)

_____ [state name of affiant signing below], being first duly sworn, deposes and says that:

1. The name of the offering company or individual is [state name of company] _____.

2. The proposal for the solicitation identified above is genuine and not collusive or a sham. The offeror has not colluded, conspired, connived or agreed, directly or indirectly, with any other offeror or person, to put in a sham proposal or to refrain from making an offer. The offeror has not in any manner, directly or indirectly, sought by an agreement or collusion, or communication or conference, with any person to fix the proposal price of offeror or of any other offeror, or to fix any overhead, profit or cost element of said proposal price, or of any other offeror, or to secure any advantage against the government of Guam or any other offeror, or to secure any advantage against the government of Guam or any person interested in the proposed contract. All statements in this affidavit and in the proposal are true to the best of the knowledge of the undersigned. This statement is made pursuant to 2 GAR Division 4 § 3126(b).

3. I make this statement on behalf of myself as a representative of the offeror, and on behalf of the offeror's officers, representatives, agents, subcontractors, and employees.

Date: _____

 Signature of one of the following:
 Offeror, if the offeror is an individual;
 Partner, if the offeror is a Partnership;
 Officer, if the bidder is a Corporation.

Subscribed and sworn to before me this _____ day of _____, _____.

 Notary Public
 My Commission expires _____

(AG Procurement Form 003 (Rev. Jul. 12, 2010))

3. AFFIDAVIT re NO GRATUITIES or KICKBACKS
GVB IFB 2024-009

Name of Offeror Company: _____

CITY OF _____)
) ss
COUNTRY _____)

_____ [state name of affiant signing below], being first duly sworn, deposes and says that:

1. The name of the offering firm or individual is [state name of offeror/company] _____
_____. Affiant is _____ [state one of the following: the offeror, a partner of the offeror, an officer of the offeror] making the foregoing identified bid or proposal.

2. To the best of affiant's knowledge, neither affiant, nor any of the offeror's officers, representatives, agents, subcontractors, or employees have violated, are violating the prohibition against gratuities and kickbacks set forth in 2 GAR Division 4 § 11107(e). Further, affiant promises, on behalf of offeror, not to violate the prohibition against gratuities and kickbacks as set forth in 2 GAR, Division 4 § 11107(e).

3. To the best of affiant's knowledge, neither affiant, nor any of the offeror's officers, representatives, agents, subcontractors, or employees have offered, given or agreed to give, any government of Guam employee or former government employee, any payment, gift, kickback, gratuity or offer of employment in connection with the offeror's proposal.

4. I make these statements on behalf of myself as a representative of the offeror, and on behalf of the offeror's officers, representatives, agents, subcontractors, and employees.

Signature of one of the following:
Offeror, if the offeror is an individual;
Partner, if the offeror is a Partnership;
Officer, if the bidder is a Corporation.

Subscribed and sworn to before me this _____ day of _____, ____.

Notary Public
My Commission expires _____



4. AFFIDAVIT re ETHICAL STANDARDS
GVB IFB 2024-009

Name of Offeror Company: _____

CITY OF _____)
) ss
COUNTRY _____)

_____ [state name of affiant signing below], being first duly sworn, deposes and says that:

The affiant is _____ [state one of the following: the offeror, a partner of the offeror, an officer of the offeror] making the foregoing identified bid or proposal. To the best of affiant's knowledge, neither affiant nor any officers, representatives, agents, subcontractors or employees or offeror have knowingly influenced any government of Guam employee to breach any of the ethical standards set forth in 5 GCA Chapter 5, Article 11. Further, affiant promises that neither he or she, nor any officer, representative, agent, subcontractor, or employee of offeror will knowingly influence any government of Guam employee to breach any ethical standards set forth in 5 GCA Chapter 5, Article 11. These statements are made pursuant to 2 GAR Division 4 § 11103(b).

Signature of one of the following:
Offeror, if the offeror is an individual;
Partner, if the offeror is a Partnership;
Officer, if the bidder is a Corporation.

Subscribed and sworn to before me this _____ day of _____, ____.

Notary Public
My Commission expires _____

(AG Procurement Form 005 (Rev. Jul. 12, 2010))



5. DECLARATION RE COMPLIANCE WITH U.S. DOL WAGE DETERMINATION
GVB IFB 2024-009

Name of Offeror Company: _____

I, _____ hereby certifies under penalty of perjury:

- (1) That I am _____ [please select one: the offeror, a partner of the offeror, an officer of the offeror] making the bid or proposal in the foregoing identified procurement;
- (2) That I have read and understand the provisions of 5 GCA § 5801 and § 5802 which read:

§ 5801. Wage Determination Established.

In such cases where the government of Guam enters into contractual arrangements with a sole proprietorship, a partnership or a corporation ('contractor') for the provision of a service to the government of Guam, and in such cases where the contractor employs a person(s) whose purpose, in whole or in part, is the direct delivery of service contracted by the government of Guam, then the contractor shall pay such employee(s) in accordance with the Wage Determination for Guam and the Northern Mariana Islands issued and promulgated by the U.S. Department of Labor for such labor as is employed in the direct delivery of contract deliverables to the Government of Guam.

The Wage Determination most recently issued by the U.S. Department of Labor at the time a contract is awarded to a contractor by the government of Guam shall be used to determine wages, which shall be paid to employees pursuant to this Article. Should any contract contain a renewal clause, then at the time of renewal adjustments, there shall be made stipulations contained in that contract for applying the Wage Determination, as required by this Article, so that the Wage Determination promulgated by the U.S. Department of Labor on a date most recent to the renewal date shall apply.

§ 5802. Benefits.

In addition to the Wage Determination detailed in this Article, any contract to which this Article applies shall also contain provisions mandating health and similar benefits for employees covered by this Article, such benefits having a minimum value as detailed in the Wage Determination issued and promulgated by the U.S. Department of Labor, and shall contain provisions guaranteeing a minimum of ten (10) paid holidays per annum per employee.

- (3) That the Offeror is in full compliance with 5 GCA § 5801 and § 5802, as may be applicable to the procurement referenced herein;
- (4) **That I have attached the most recent wage determination applicable to Guam issued by the U.S. Department of Labor.**

Signature Date

(AG Procurement Form 006 (Rev. Feb. 16, 2010))



6. AFFIDAVIT re CONTINGENT FEES
GVB IFB 2024-009

Name of Offeror Company: _____

CITY OF _____)
) ss
COUNTRY _____)

_____ [state name of affiant signing below], being first duly sworn, deposes and says that:

1. The name of the offering company or individual is [state name of company] _____

2. As a part of the offering company’s bid or proposal, to the best of my knowledge, the offering company has not retained any person or agency on a percentage, commission, or other contingent arrangement to secure this contract. This statement is made pursuant to 2 GAR Division 4 11108(f).

3. As a part of the offering company’s bid or proposal, to the best of my knowledge, the offering company has not retained a person to solicit or secure a contract with the government of Guam upon an agreement or understanding for a commission, percentage, brokerage, or contingent fee, except for retention of bona fide employees or bona fide established commercial selling agencies for the purpose of securing business. This statement is made pursuant to 2 GAR Division 4 11108(h).

4. I make these statements on behalf of myself as a representative of the offeror, and on behalf of the offeror’s officers, representatives, agents, subcontractors, and employees.

Signature of one of the following:
Offeror, if the offeror is an individual.
Partner, if the offeror is a partnership.
Officer, if the offeror is a corporation.

Subscribed and sworn to before me this _____ day of _____, ____.

Notary Public
My Commission expires _____

(AG Procurement Form 007 (Rev. Jul. 15, 2010))

**7. AFFIDAVIT RESTRICTION AGAINST CONTRACTORS EMPLOYING CONVICTED
SEX OFFENDERS FROM WORKING AT GOVERNMENT OF GUAM VENUES
GVB IFB 2024-009**

Name of Offeror Company: _____
CITY OF _____)
COUNTRY _____) ss

_____, being first duly sworn, is _____
(NAME OF PERSON) PLEASE STATE "INDIVIDUAL"

_____ of _____
IF SOLE PROPRIETOR; "PARTNER" IF A PARTNERSHIP; OR "OFFICER" OF A CORPORATION (NAME OF OFFEROR)

_____ TEL: _____
(MAILING ADDRESS) (TELEPHONE NUMBER)

and a duly authorized representative of said offeror on whose behalf this affidavit is being submitted. Said offeror has affirms that he/she has read and understands the provisions of **5 GCA, CHP 5 §5253 RESTRICTION AGAINST CONTRACTORS EMPLOYING CONVICTED SEX OFFENDERS FROM WORKING AT GOVERNMENT OF GUAM VENUES.**

The offeror understands that:

- (1) No person convicted of a sex offense under the provisions of Chapter 25 of Title 9 Guam Code Annotated, or an offense as defined in Article 2 of Chapter 28, Title 9 GCA in Guam, or an offense in any jurisdiction which includes, at a minimum, all of the elements of said offenses, or who is listed on the Sex Offender Registry, and who is employed by a business contracted to perform services for an agency or instrumentality of the government of Guam, shall work for his employer on the property of the government of Guam other than a public highway.

Further, the offeror represents:

- (1) that no person providing services on behalf of the contractor has been convicted of a sex offense under the provisions of Chapter 25 of Title 9 GCA or an offense as defined in Article 2 of Chapter 28, Title 9 GCA, or an offense in another jurisdiction with, at a minimum, the same elements as such offenses, or who is listed on the Sex Offender Registry; and,
- (2) that if any person providing services on behalf of the contractor is convicted of a sex offense under the provisions of Chapter 25 of Title 9 GCA or an offense as defined in Article 2 of Chapter 28, Title 9 GCA or an offense in another jurisdiction with, at a minimum, the same elements as such offenses, or who is listed on the Sex Offender Registry, that such person will be immediately removed from working at said agency and that the administrator of said agency be informed of such within twenty-four (24) hours of such conviction.

Signature

Subscribed and sworn to before me this _____ day of _____, _____.

Notary Public
My Commission expires _____

SECTION IX PAST PERFORMANCE QUESTIONNAIRE

GVB IFB 2024-009
Title: **COMMUNITY DEVELOPMENT LIGHTING PROJECT**

[PROVIDE THIS PPQ TO THOSE ON YOUR PROJECT REFERENCES. REQUEST THAT THEY COMPLETE AND SUBMIT DIRECTLY TO GVB ON OR BEFORE THE DEADLINE FOR THIS PROCUREMENT.]

COMPANY NAME: _____
[PLEASE CLEARLY TO IDENTIFY THE COMPANY THIS PPQ IS REFERENCING]

PLEASE RETURN THIS COMPLETED QUESTIONNAIRE BY EMAIL TO: procurement@visitguam.org

CONTACT DETAILS OF PERSON COMPLETING THIS QUESTIONNAIRE:

Name: _____ Telephone Number: _____

Title: _____ Email Address: _____

Name of your company/organization: _____

1. Please briefly describe the type of services performed for your organization by the COMPANY. (Name of project, types of services performed -- analysis, training, technical support, etc.):

Comment: _____

2. Were any unique techniques or tools employed for the delivery of the services? Were the tools/techniques employed effectively?

Comment: _____

3. How would you rate the COMPANY'S ability to learn/understand your organization or the project needs/requirements?

- ___ Excellent (Score 10 points)
- ___ Very Good (Score 8 points)
- ___ Good (Score 5 points)
- ___ Poor (Score 0 points)

4. How would you rate the COMPANY'S knowledge and experience in providing the requested technical services?

- ___ Excellent (Score 10 points)
- ___ Very Good (Score 8 points)
- ___ Good (Score 5 points)
- ___ Poor (Score 0 points)

PPQ FOR: _____

5. How would you rate the COMPANY'S ability to identify and recommend resolutions to problems or issues?

- Identified and recommended quickly (Score 10 points)
- Identified and recommended slowly (Score 8 points)
- Identified but not recommended (Score 5 points)
- Were ignored (Score -0 points)

6. How would you rate the overall quality of the COMPANY'S technical services?

- Excellent (Score 10 points)
- Very Good (Score 8 points)
- Good (Score 5 points)
- Poor (Score 0 points)

7. Do you recall the name(s) of the COMPANY'S employees who performed services under your contract? If so, please provide names below.

Comment: _____

8. Overall Performance: On a scale of 0 to 10, how would you rate the COMPANY'S OVERALL PERFORMANCE? (Score based upon # of points – 10 points max)

- Excellent (Score 10 points)
- Very Good (Score 8 points)
- Good (Score 5 points)
- Poor (Score 0 points)

9. Would you enter into a contract with this COMPANY again? If not, why?

Comment: _____

10. Are you aware of any other company or organization this COMPANY has done work for? If so, do you have a contact name and phone number?

Name: _____ Phone Number: _____

Other contact information: _____

11. Do you have any additional comments that might assist us in evaluating the Bidder's past performance?

Comment: _____

PLEASE RETURN COMPLETED QUESTIONNAIRE BY EMAIL ON OR BEFORE 12:00 PM ChST ON September 27, 2024 TO procurement@visitquam.org. Thank you for your cooperation.

APPENDIX A SCOPE OF WORK AND TECHNICAL SPECIFICATIONS

OBJECTIVE

The Guam Visitors Bureau is dedicated to promoting Guam as a world-class destination, enhancing visitor experiences, and supporting the island's tourism industry. Through strategic marketing, community engagement, and cultural preservation, GVB strives to enrich the lives of both residents and visitors.

To justify procurement planning for this Community Development Lighting Project, it is essential to highlight the benefits, the thorough planning process, and the alignment with strategic goals. The project aims to enhance safety, promote tourism, and improve the quality of life for both residents and visitors by installing solar-powered streetlights in key tourist sites and noticeably darkened areas frequently used by members of our community.

Project Overview: This project is a strategic initiative by the Guam Visitors Bureau (GVB) and the Government of Guam to install solar-powered LED streetlights as a community development project primarily along Government Hill toward and including Government House in Agana Heights, as well as the Adelup Complex in Anigua. The project builds on the success of a pilot program in Tumon and other areas, which significantly improved safety for pedestrians and drivers, receiving positive feedback from both the local community and tourists. Government Hill and the Adelup Complex has long been utilized by many health-conscious individuals take on their daily exercise route. Lighting up these areas will definitely be a great improvement and morale boost for them and other pedestrians and drivers alike who appreciate the efforts made toward their safety.

1. **Strategic Alignment and Public Safety:** The project directly supports the strategic objectives of enhancing Guam's image as a safe, attractive tourist destination. Improved lighting in dark, high-traffic areas is critical for reducing crime and accidents, contributing to both visitor satisfaction and resident well-being. This aligns with the goals set by the Guam Visitors Bureau and the Governor of Guam to boost tourism while ensuring public safety.
2. **Proven Effectiveness and Community Support:** GVB's prior tests and evaluations of solar-powered LED streetlights demonstrated their effectiveness in increasing visibility and safety. Community feedback from the pilot project in Tumon confirmed that such infrastructure improvements are both necessary and highly beneficial.
3. **Comprehensive Procurement Planning:** The project involves a well-planned procurement process, including:
 - a. **Needs Assessment:** GVB performed a needs assessment to identify lighting requirements, such as retrofitting existing poles and determining if there was a need to install new ones.
 - b. **Pilot Testing and RFQs:** Much of the testing and assessments were done during the Tumon project's pilot phase to test different LED lighting solutions, ensuring the best options were selected for this larger-scale project; however, there was a physical site inspection completed to assess the need and type(s) of lighting material required for this project.
 - c. **Implementation:** It is important to proceed with implementation of this project as soon as possible to address the much-needed demand for enhancing safety and improving the quality of life for both residents and visitors in the central area identified herein.
 - d. **Funding and Economic Justification:** The project is funded through the American Rescue Plan (ARP) funds, which allows GVB to implement the project without straining local resources

while addressing critical infrastructure needs that contribute to economic recovery by attracting more tourists to Guam.

e. **Long-Term Sustainability:** Solar-powered LED lights are energy-efficient, environmentally friendly, and cost-effective over time. The reduction in energy costs and the use of sustainable technology make this project a sound investment for the island's long-term development.

4. **Collaboration and Stakeholder Engagement:** The project involves collaboration with multiple government agencies, including the Department of Public Works (DPW), the Department of Parks and Recreation (DPR) and the Governor's office. This ensures that technical specifications, site assessments, and installation processes are handled efficiently. A Memorandum of Agreement (MOA) between the Governor and GVB outlines the rights and responsibilities regarding the installation and maintenance of the streetlights.

5. **Performance and Accountability:** Clear performance metrics, including timely installations, community feedback, and safety impact assessments, will be used to evaluate the project's success. Regular reporting and oversight will ensure transparency and accountability throughout the procurement and implementation phases.

This project represents a strategically important investment in the island's infrastructure, enhancing safety and supporting the growth of Guam's tourism industry. The comprehensive planning, phased implementation, and sustainable design ensure that the project will deliver long-term benefits for both residents and visitors. The procurement planning is fully justified based on the proven need, positive pilot results, strategic funding, and alignment with government objectives.

SCOPE OF WORK

This solicitation is to secure the services of a company for the removal and disposal of existing streetlights, and to fully replace them with Solar LED panels as required in the technical specifications provided.

The units shall be as close to or comparable to the photos and description in the Bid Specifications detailed in this Appendix. The equipment shall be new/unused current model year or later production.

The Solar LED Streetlights shall be supplied with all standard equipment and accessories as indicated in the manufacturer's published literature/brochure.

The timeline for completion of this project is 60 days from award.

The general area for installation will be as follows:

| LOCATION | # OF POLES | # OF LED SOLAR LIGHTS | LIGHT TYPE |
|----------------------------------|------------|-----------------------|------------|
| Govt House/Govt Hill | 55 | 110 | 100w |
| Adelup Complex (7 ¼" dimensions) | 22 | 44 | 100w |
| Adelup Complex (5 ¼" dimensions) | 3 | 6 | 100w |

ESTIMATED TOTAL: **80** **160**



TECHNICAL SPECIFICATIONS: Type of LED Solar Lights Required

100 Watt Solar Lights

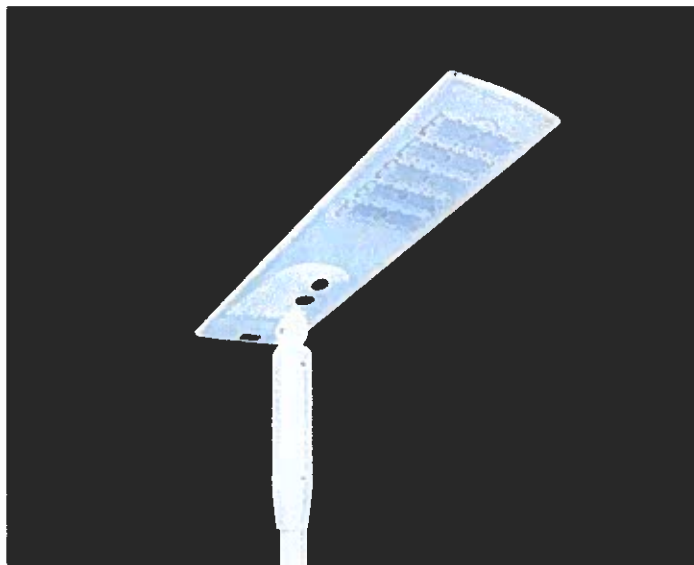

Type : 100W Solar Street Lights

LED Chips: Philips 400 pieces

lumen: 10,000-12,000

CRI: >70

CGT: 3000-6500K

Lamp beads: Philips 2835

Degree Protection: IP65

Battery Type: Lithium iron phosphate battery

Lamp Body: Die-Cast Aluminum

Lens Material: PC(75*140)

Solar Panel: Monocrystalline Silicone (18v*150w)

Working Hours: 5 Rainy days

Working method: Stays bright without motion sensor

Adjustable Angle: 180 degrees

Charging hours: 6 hours

Installation Diameter: 76mm/80mm

Gross Weight: 66lb

Certificates: FC,UL,CE, ROHS, GS, ETL, BSCI, ISO9001

Warranty: 1 year from the date delivered

SPECIFICATIONS AT LOCATION: Government Hill & Government House

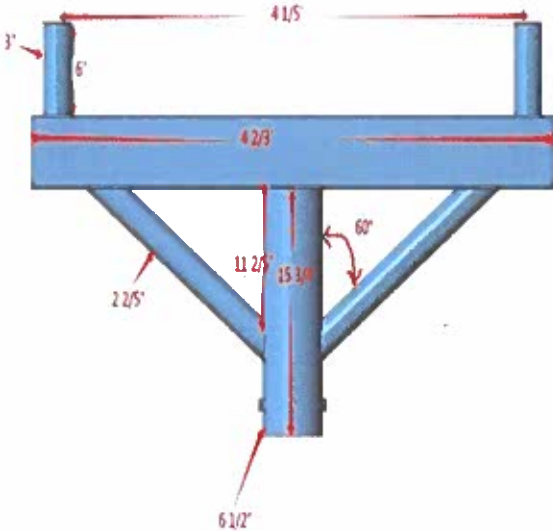

(A) POLE BRACKET ASSEMBLY

Material Type: Galvanized metal
Thickness: 3mm
Dimensions: Please refer to diagram
Finish: Powder coated paint
Color: Black



Current installed sample
double sided brackets
Bracket pole: 55
light type: 100w
Qty: 110

SPECIFICATIONS AT LOCATION: Adelup Complex

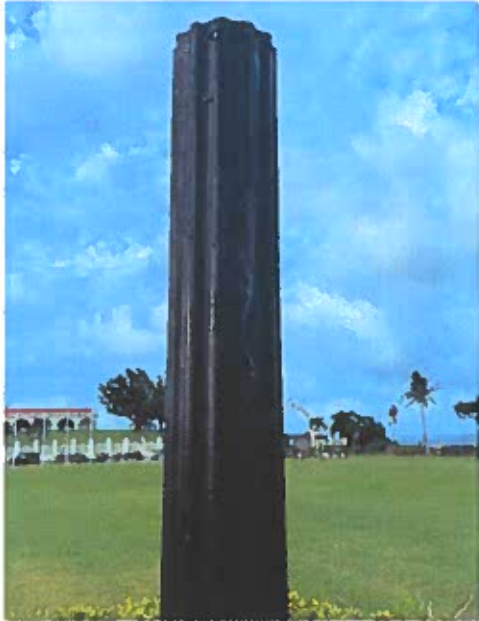

(B) POLE BRACKET ASSEMBLY

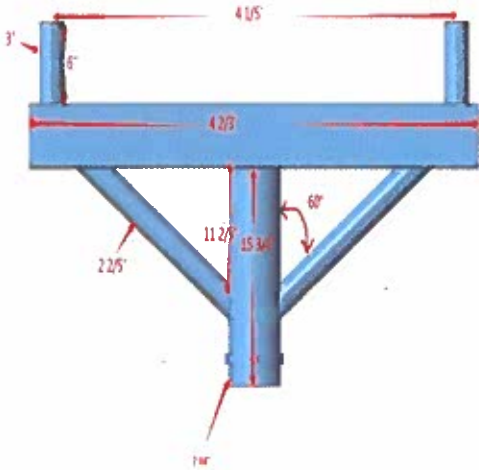

Type: Galvanized steel pipe
 Thick: 3mm
 Bottom mount dimensions: 7 1/4"
 Number of poles: 22
 Type of lights: 100w
 Number of lights: 44

(C) POLE BRACKET ASSEMBLY

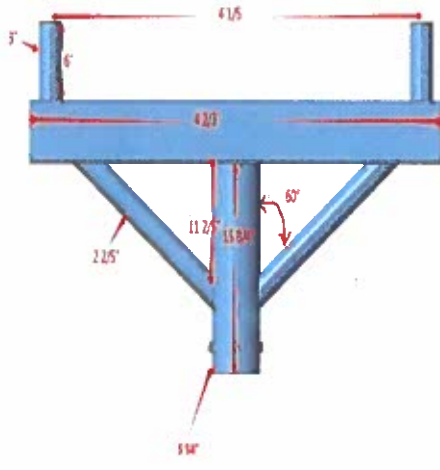

Type: Galvanized steel pipe
 Thick: 3mm
 Bottom mount dimensions: 5 1/4"
 Number of poles: 3
 Type of lights: 100w
 Number of lights: 6

APPENDIX B BID SCHEDULE

| SUBMITTED BY: _____ | | | | | |
|---------------------|--|------|-----|----------------|--------------|
| BID ITEM NO. | BID ITEM DESCRIPTION | UNIT | QTY | UNIT BID PRICE | BID AMOUNT |
| 1 | Mobilization | LS | | | |
| 2 | Traffic Control | EA | | | |
| 3 | Light Fixture Assembly (100W) | EA | 160 | | |
| 4 | (A) Pole Bracket/Fixture Assembly Complete | EA | 55 | | |
| 5 | (B) Pole Bracket/Fixture Assembly Complete | EA | 22 | | |
| 6 | (C) Pole Bracket/Fixture Assembly Complete | EA | 3 | | |
| 7 | Disposal and applicable fees for replaced street and sidewalk lights | LS | | | |
| 8 | Warranty/Service – 1 year | LS | | | |
| 9 | Contingency (include this amount in your total bid) | LS | | \$ 50,000.00 | \$ 50,000.00 |
| 10 | TOTAL Bid Amount | | | | |

1. Except for mobilization, the unit price of each item should be based on installation including clean up and securing jobsite.
2. All Equipment and Materials shall be priced as installed, except where marked for recommended stock inventory.

